

BETENBENDER

Manufacturing, Inc.

AMERICAN MADE WITH PRIDE & DURABILITY

**Retrofit Backguages
Shears & Press Brakes**

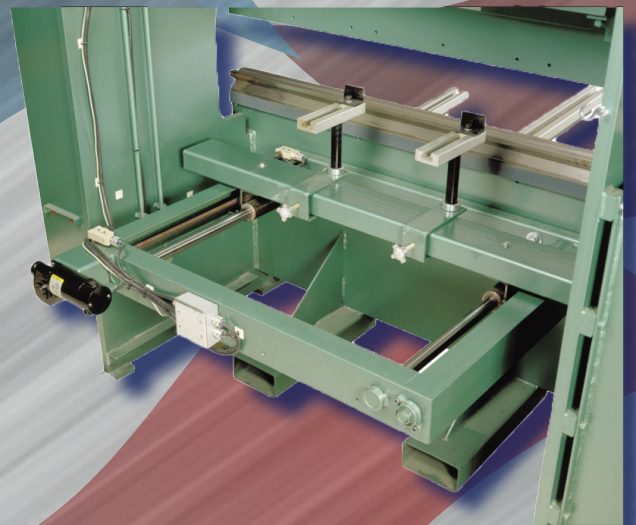
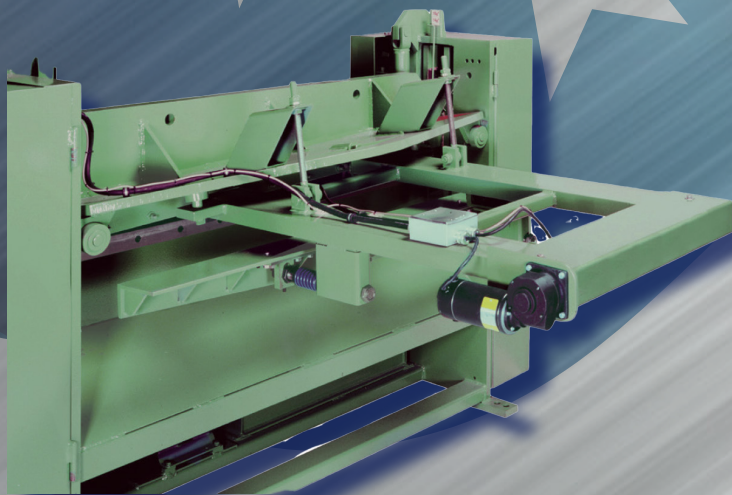
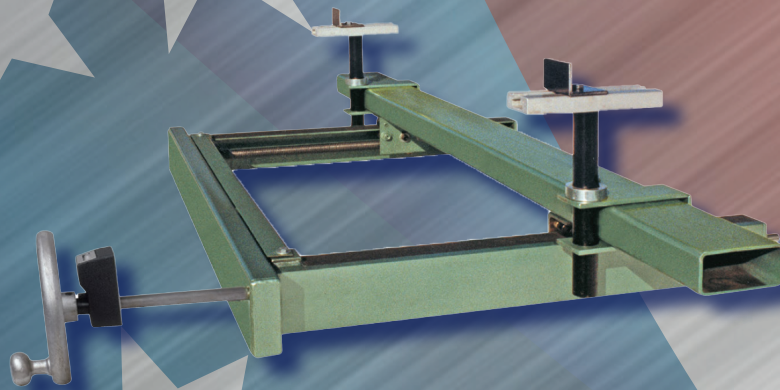

*The Betenbender Family of American Made
Hydraulic Shears and Press Brakes
Since 1972*

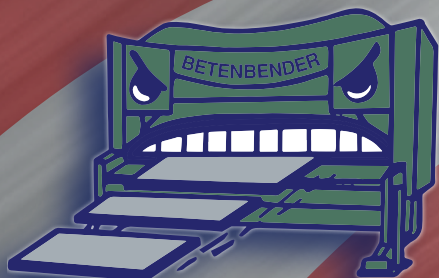

Located in Coggon, Iowa

Also on the Web at
www.betenbender.com

HMI
Hydraulic Machines of Iowa

Shears

Press Brakes

C Frame Presses

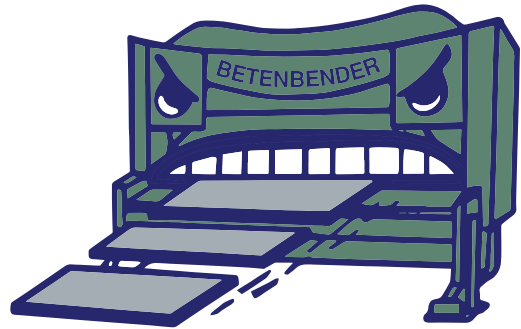

If you're not already a customer of Betenbender Manufacturing, Inc. we welcome you as a future owner of an American made Betenbender Hydraulic Shear, Hydraulic Press Brake or C Frame Press. If you've purchased one before, we welcome you back. We are pleased that our customers come back again and again, as they grow and need more equipment.

Our full range of Hydraulic machines are engineered for simplicity and ease of operation. We have a national and international sales and service team ready to serve you.

Since 1972 we have continually updated our designs and equipment to meet our customers' needs. We always appreciate and welcome feedback from our customers.

Max Betenbender

-Max Betenbender, President

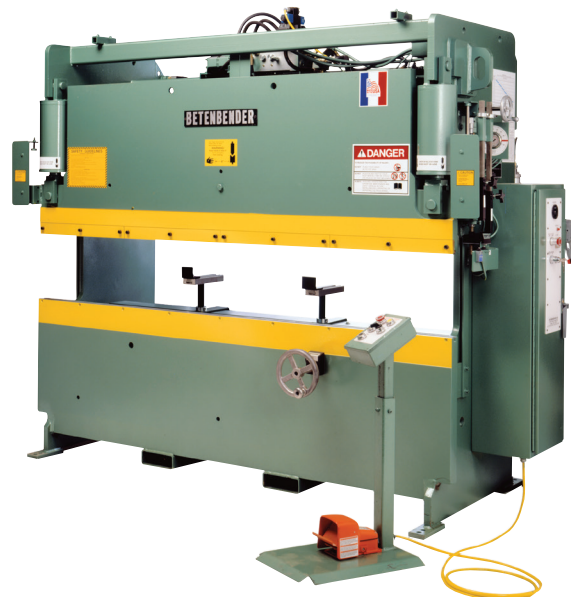

ABOUT US



1971



2014

Our History

The Betenbender Family of American Hydraulic Shears and Hydraulic Press Brakes is made by Betenbender Manufacturing, Inc. in Coggon, Iowa, U.S.A. Now in our fifth decade in business, our Midwestern Company continues to produce what we believe is America's best built Shears and Press Brakes.

Glen (Pete) Betenbender began as a blacksmith in Coggon during the 1930s. During WWII, he ran a small fabrication and repair shop. In 1948 he and his wife, Blanche, moved their growing business into their current location as a repair and manufacturing facility. Their son, Max, joined the company in 1967 after serving in the United States Army. In 1972, Pete and Max built their first shear for their own use, but demand from other local businesses for their shear prompted the Betenbenders to begin producing shears for national and international resale. In 1984 Betenbender Manufacturing, Inc. got its first contract to produce shears for a major company.

In 2012, Betenbender Manufacturing, Inc. purchased Hydraulic Machines, Inc. from long time friends, Alan and Whitney Hanner. Under the HMI (Hydraulic Machines of Iowa) name we offer a line of C frame presses ranging from 35 ton to 200 ton.

Betenbender Manufacturing, Inc. continues to be a family owned business. Today Max is President and his wife, Donna, is the corporations Secretary-Treasurer. The Vice President, Kyle Rawson, handles the operation of the manufacturing facility which includes customer service and fabrication.

Today there are over 3,900 Betenbender machines in use with very few on the used market.

We have always said...



This Betenbender Shear, one of our first machines-built in 1972, is still in operation!



High Profile Shear - 2004

“If it says Betenbender on the nameplate, you’ve got a machine that will do the job.”



BACKGAUGES FOR SHEARS

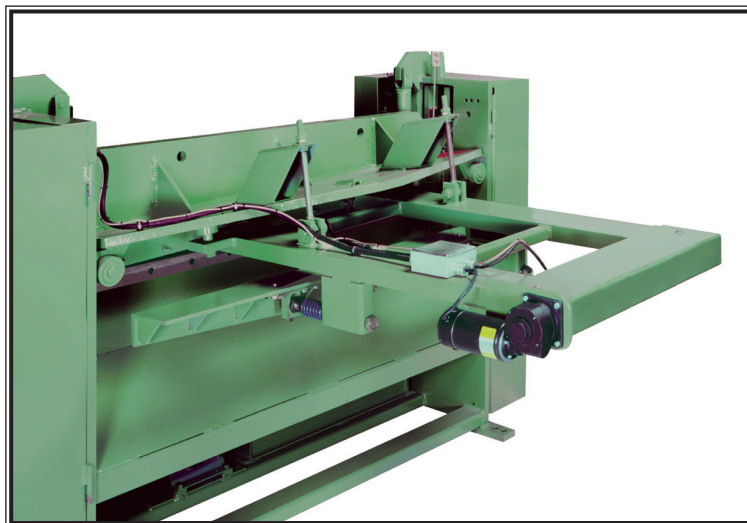

Backgauges available in
4' - 12' bar lengths.
Longer lengths...P.O.R.

Backgauges for machines
3/8" and larger... P.O.R.

#92MB

Backgauge Package:

Rear Operated Manual Backgauge, with Spring Loaded Backbar,
Mechanical Readout and Handwheel.

#92FBEL-GT

Backgauge Package:

Front Operated Electric, Front Operated Backgauge
with Single Axis 5-Station "GO-TO" Positioner and Spring Loaded Backbar
Controls located in NEMA 12 box.

#92EVL-GT

Controller Package: (For Existing Manual Operated Backgauges)

Electric, Front Operated, Single Axis 5-Station "GO-TO"
Located in NEMA 12 box

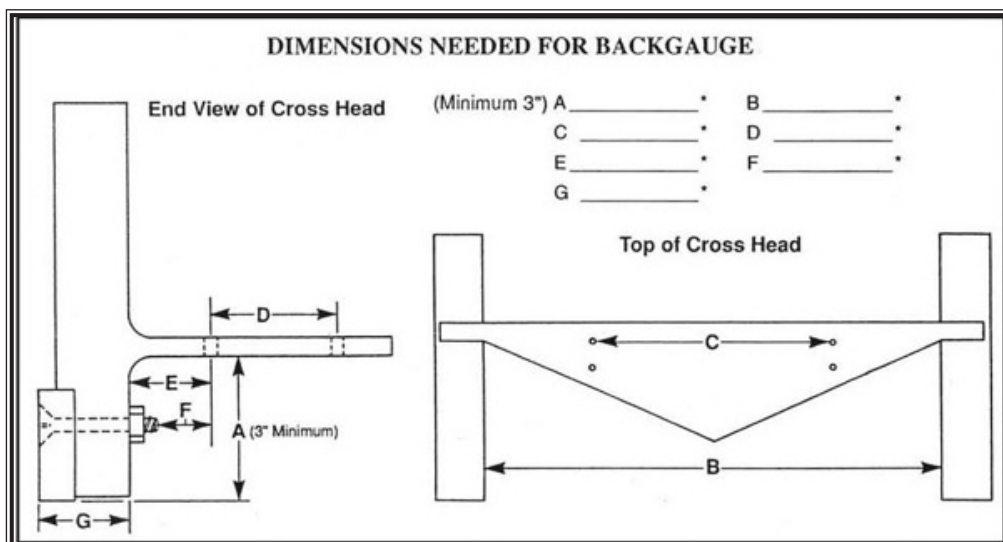

PRESS BRAKES

BACKGAUGES FOR PRESS BRAKES

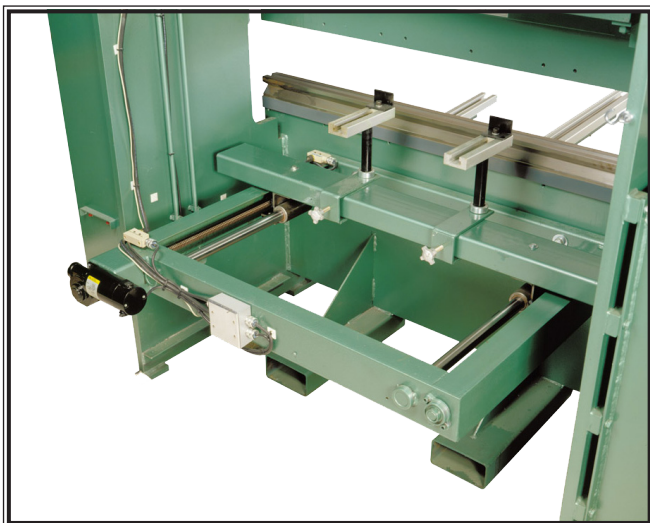

Backgauges available in
4' - 12' bar lengths.
Longer lengths...P.O.R.

#94MB24

Front Operated Manual Backgauge (24") with Mechanical Digital Readout

#94FOP24-GT

Front Operated Power Backgauge
Single Axis 5-Station "GO-TO" Positioner
Does not include swing arm pendant

#94FOP24-GT-AS

Front Operated Power Backgauge with
Auto Sequence Axis 5-Station "GO-TO" Positioner
Does not include swing arm pendant

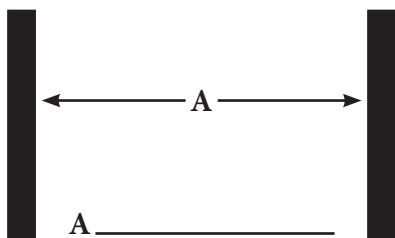

(Specify distance between
housing in inches when ordering)

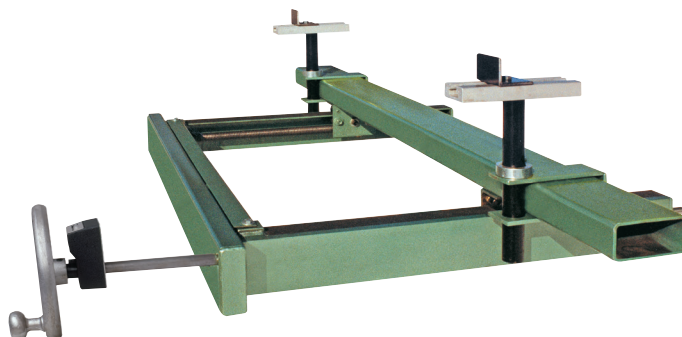

**Some Modifications may be Required
to Adapt to Your Machine**



99 Station
Auto Sequence

THANK YOU

Serial Numbers & Oil Information

Model No.	Serial No.
BETENBENDER MANUFACTURING, INC.	
	5806 Quality Ridge Rd PO Box 140 Coggon, IA 52218 319-435-2378 www.betenbender.com
	
WE RECOMMEND THE FOLLOWING LUBRICANTS:	
Hydraulic Oil.....Mobil DTE 25 Grease Points.....Lubriplate 930-AA	
AMERICAN MADE WITH PRIDE AND DURABILITY SINCE 1972	
For Mobil product information, please call 1-800-662-4525	



An International System



No matter where you are, there is a Betenbender Manufacturing, Inc. representative available.

Our full line of American-Made Hydraulic Shears, Press Brakes, and C Frame Presses are represented by statewide dealers and serviced by regional distribution and service offices.

International dealers -- we ship and market worldwide.

Call to find out who your personal representative is -- **319-435-2378**

Or email -- **sales@betenbender.com**

Or visit our website -- **www.betenbender.com**

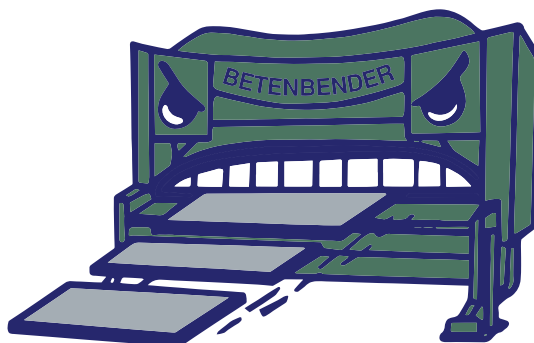

All machines are made in the heartland of the USA in Coggon, Iowa